

DATA SHEET

KIO215L SLIM KIOSK

Introducing our next generation in industrial kiosks. Our clever design of our 21.5" landscape kiosk will draw your customers in with it's incredible sleek form factor. New to our extensive range of kiosks, the KIO215L-SLIM is perfect for so many applications including queue management, self-check in, self-order and payment.

The visually appealing slimline design with soft corners, trendy tapers and edge-to-edge glass make it suitable for showrooms, retail stores and other environments requiring an elegant solution. The solid steel construction, commercial components and toughened glass make it also suitable for harsher, high-traffic environments or other locations that require a rugged solution.



The ergonomic screen height and angle have been expertly designed so that the kiosk can be comfortably interacted with by anyone, from a standing or seated position.

KIOSK FEATURES

- Australian designed, manufactured & supported
- Robust steel construction, durable powder-coated finish
- Free-standing design with option to bolt down base plate
- Power & data feed from wall or floor through the base plate
- Cooled with a multi-speed fan and louvers
- Key lockable access door, tamper resistant design

- Internal PC shelf (PC sold separately or supply your own)
- 3 year RTB warranty included

DISPLAY FEATURES

- 21.5" commercial-grade touch screen
- 10-point PCAP multi-touch technology
- Full HD 1920 x 1080 (16: 9 widescreen) resolution
- High clarity display with protective toughened glass
- Windows 10 compatible, driver free, plug-and-play
- Supports multi-touch gestures including pan, pinch & zoom



AUSTRALIAN MADE



3-YEAR WARRANTY



10 POINT MULTI-TOUCH



EASY SET UP

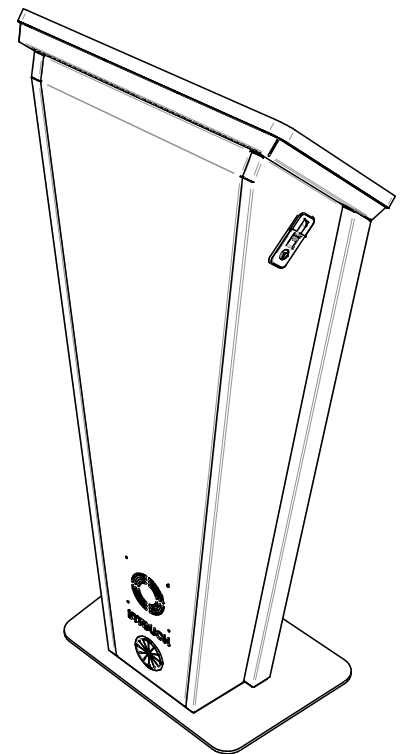
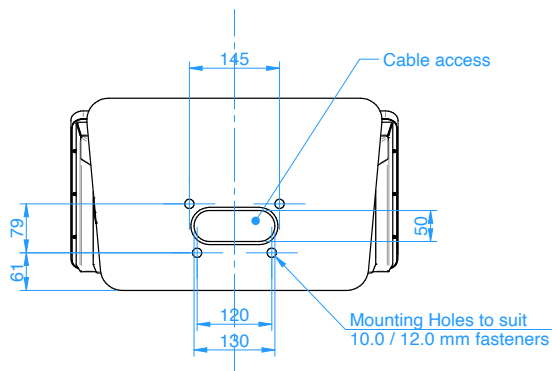
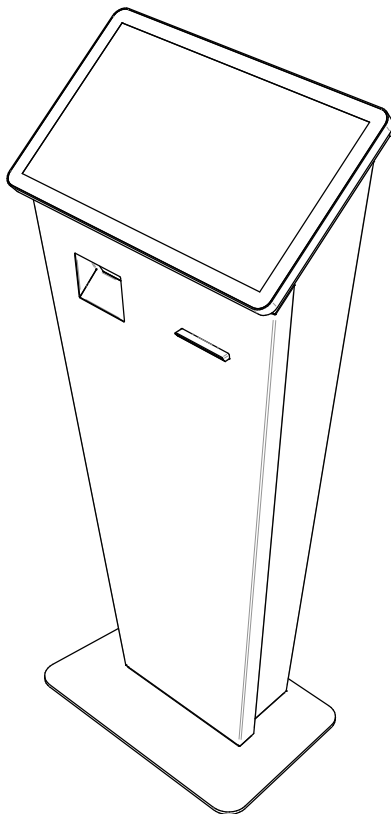
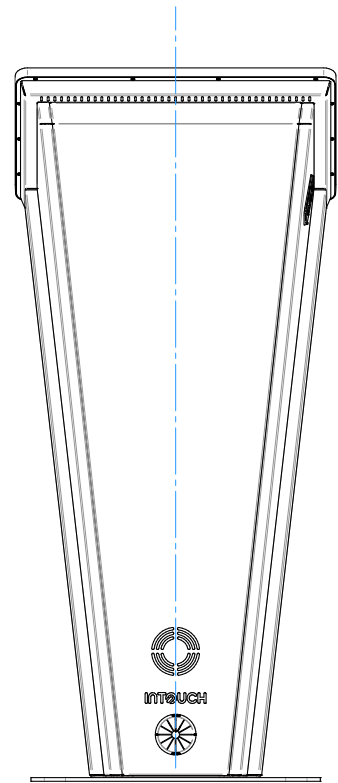
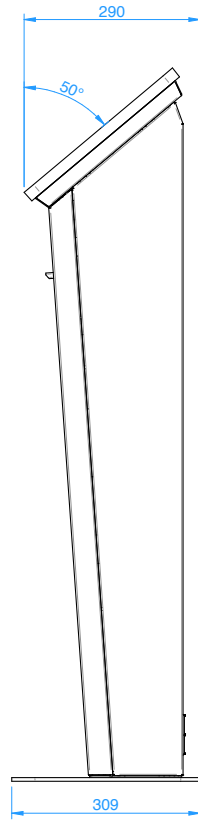
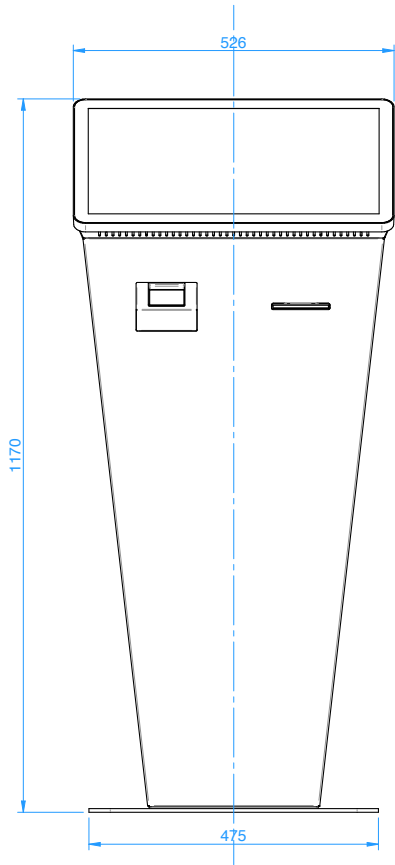

ILLUSTRATED WITH OPTIONAL PRINTER & BARCODE SCANNER

Interchangeable Front Fascia

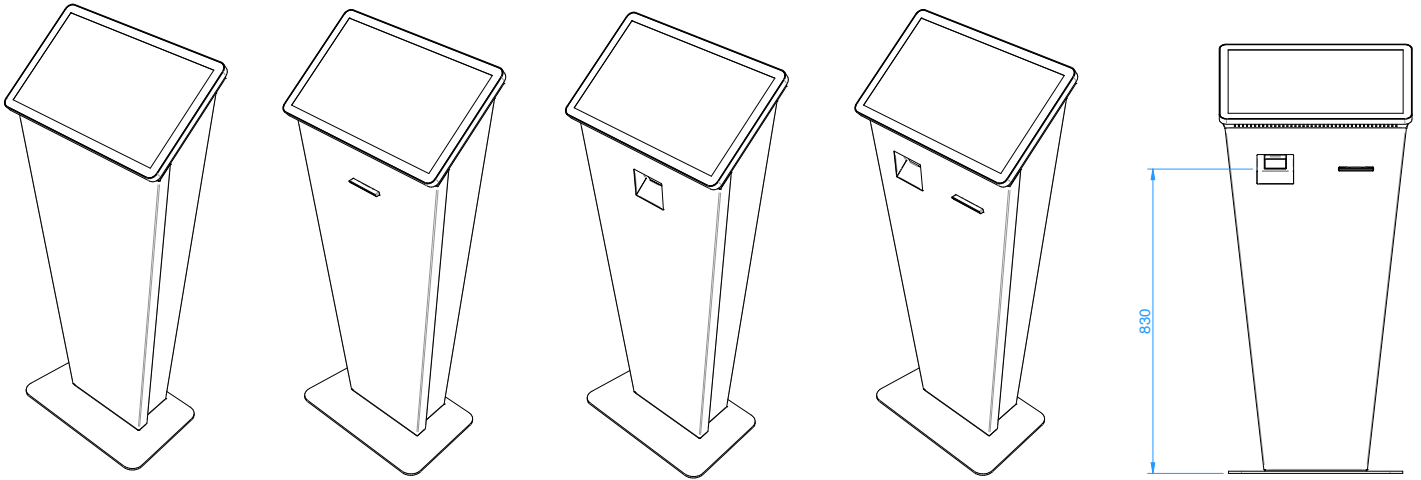

Standard

Industrial Thermal Receipt Printer

2D Barcode & QR Code Scanner

Combined Fascia
2D Barcode or QR Code Scanner & Industrial Thermal Receipt Printer

NOTE: Each assembly uses a different front panel.
The internal mounting brackets for the Printer and Scanner are the same for each configuration

Kiosk Options

- Custom logo & branding
- Thermal receipt printer
- Magnetic card reader
- QR/Barcode scanner
- Interchangeable black and white front fascias
- Four front panel options: Plain, printer only, scanner only and printer + scanner openings
- Fixed & adjustable camera mounting options
- EFTPOS Payment terminal bracket

Technical Specifications

- 1920 x 1080 Full HD resolution
- 21.5" active viewable area
- 16:9 aspect ratio
- 250 cd/m2 brightness
- 1000:1 contrast ratio
- 10-point PCAP multi-touch
- HDMI & VGA input
- USB touch interface
- Built-in stereo speakers
- Energy efficient LED technology
- 36.5kg weight (Total kiosk weight)
- Compatible with Windows 10 and 11

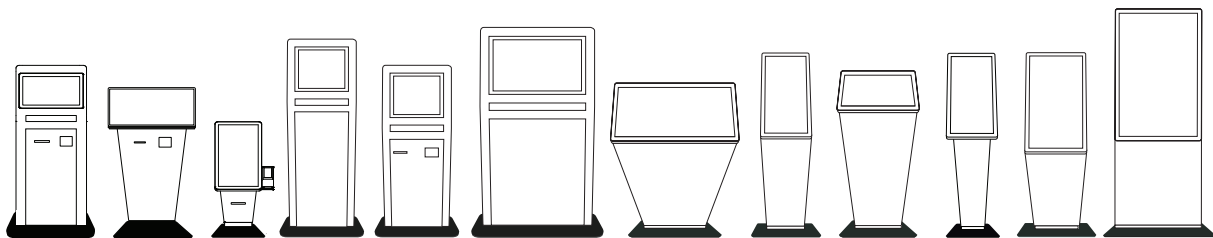

Our interactive kiosks are available in sizes from 19" - 42" to suit any application and available installation space.

InTouch Screens

Unit 1, 3 Green Street, Brookvale NSW 2100
1300 557 219

InTouchScreens.com.au | Sales@intouchscreens.com.au

INTOUCH